

OPERATING MANUAL

CONSIGNES DE FONCTIONNEMENT

INSTRUCCIONES DE FUNCIONAMIENTO



KS SERIES

LASER TRANSMITTER



MODEL

KS 100H



Dave White's

SitePro

IMPORTANT:
Read Before Using

IMPORTANT:
Lire avant usage

IMPORTANTE:
Leer antes de usar

Set Your Sights On Precision and Accuracy with Dave White's SitePro

Thank you for your purchase of our laser instrument. The purpose of this user's guide is to acquaint you with your instrument, its components, safety, proper care, and handling.

Our instruments are constructed to withstand rugged field use. Like all precision instruments, however, they should be treated with reasonable care to prolong life and accuracy.

IMPORTANT! All instruments are adjusted when they are shipped from the factory. It is the customer's responsibility to check and to ensure instruments are adjusted prior to using.

A accuracy check is recommended before the initial use of your instrument, and then periodically from that point forward (**see Accuracy Check**). If your instrument is dropped or you have uncertainty, then return it to your reseller for a calibration check and adjustment if needed.

David White® Brand is exclusive of Dave White's SitePro LLC. SitePro is not responsible for errors caused by instruments that are out of adjustment. It is important that you read the entire instruction manual before use of this instrument for care and maintenance.

We would appreciate your feedback on this product or any other product comments or suggestions. Please send to **info@dwsitepro.com**



KS 100H Rotary Laser

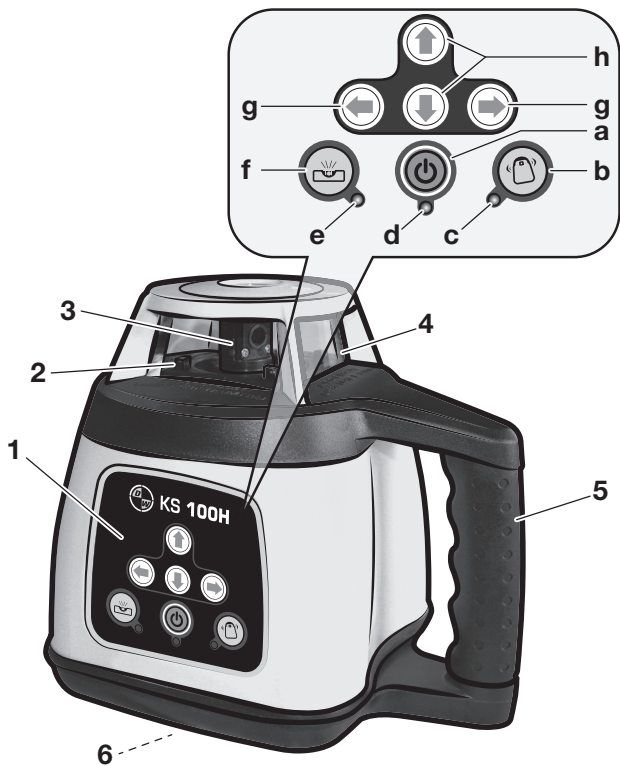



KS 100H Rotary Laser

Battery Compartment -
Bottom of Instrument

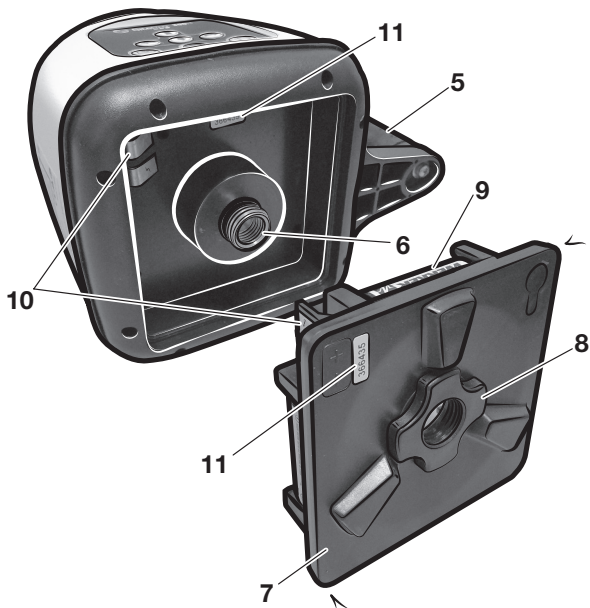

INTENDED USE

The instrument is intended for determining and checking precise horizontal lines and level. The instrument is suitable for outdoor use.

FEATURES

The numbering of the product features shown refers to the illustration of the instrument on the graphic page.

1. Control Keypad
- 1a. Power Button
- 1b. Anti-Drift System (ADS) Button
- 1c. ADS Indicator
- 1d. Battery/Power Indicator
- 1e. Manual Mode/X Axis Indicator
- 1f. Manual Mode Button
- 1g. Slope Adjustment Button (X axis)
- 1h. Slope Adjustment Button (Y axis)
2. Remote Sensor
3. Rotating Laser Beacon
4. Glass Lighthouse
5. Carrying Handle
6. 5/8-11 Tripod Mount
7. Battery Compartment Tray
8. Knob for Battery Door
9. Battery (x4)
10. Electrode Connectors
11. Serial Number

PREPARATIONS

Inserting/Replacing Battery

Alkaline batteries are suitable for use to power your instrument.

 **WARNING** Replace all alkaline batteries at the same time. Only use batteries from one brand and with the identical capacity.

Remove the batteries from the tool when not using it for extended periods. When storing for extended periods, the batteries can corrode and discharge themselves.

To open the battery compartment tray **7**, unscrew the knob **8**. Remove

compartment door. Remove battery tray **7** from unit. Remove batteries.

When inserting alkaline batteries, pay attention to the correct polarity according to the representation on the inside of the battery compartment.

Always replace all batteries at the same time. Only use batteries from one brand and with the identical capacity.

Install the battery tray onto base. Be certain that electrode connectors **10** align properly. Secure by tighten the knob **8** onto the bottom of instrument base.

OPERATION

⚠ WARNING Do not subject the instrument to

extreme temperatures or variations in temperature. As an example, do not leave it in vehicles for long time. In case of large variations in temperature, allow the instrument to adjust to the ambient temperature before putting it into operation. In case of extreme temperatures or variations in temperature, the accuracy of the instrument can be impaired.

Avoid heavy impact to or falling down of the instrument. After severe exterior effects to the instrument, it is recommended to carry out an accuracy check each time before continuing to work.

This instrument has been calibrated to precise accuracies at the factory. However, an accuracy check is recommended before the initial use of the instrument and then periodically.

See Accuracy Check.

Setting Up the Instrument

Position the instrument on a firm surface, mount it to a tripod or to the wall mount with alignment unit. Due to the high leveling accuracy, the instrument reacts sensitively to ground vibrations and position changes. Therefore, pay attention that the position of the instrument is stable in order to avoid operational interruptions due to re-leveling.

Switching On and Off

To **switch on** the instrument, press **⏻ 1a**. The instrument automatically starts leveling and the Battery/Power Indicator **1d** illuminates, the laser flashes.

The instrument is leveled in as soon as the laser beam starts rotational operation.

The laser instrument can stand alone on a level, sturdy surface or preferably secured to a 5/8-11 tripod.

If the instrument is placed improperly, or the slope of instrument exceeds the range of $\pm 5^\circ$, the Manual Mode Indicator **1e** flashes green and the laser beam flashes. Reposition the instrument that it is more horizontal or level.

To **switch off** the instrument, press and hold the power button **⏻ 1a**.

Anti-Drift System (ADS)

ADS alerts user when laser has been disturbed. Allow the instrument is self-level and laser beam starts to rotate.

To activate, first check to ensure your work set points are accurate. Then press the **Ⓢ** Anti-Drift System (ADS) Button **1b**. The ADS Indicator **1c** will flash green. ADS will activate.

If instrument is disturbed, the laser beams will stop rotating and flash. ADS Indicator **1c** will flash rapidly green.

To reactivate, first press  Anti-Drift System (ADS) Button **1b** to disable ADS and allow instrument to relevel. The instrument will re-level and laser beam will start rotational operation.

⚠ IMPORTANT Check to ensure your work set points are accurate before you reactivate ADS.

Press the  Anti-Drift System (ADS) Button **1b**. The ADS Indicator **1c** will flash green. ADS will activate.

In rough environments this function may not be useful. You can disable the anti-drift system.

To disable ADS, press  **1b** once. The ADS Indicator **1c** will turn off. ADS will deactivate.

Manual Mode

Manual mode operation disengages the self-leveling operation. This allows the instrument to be placed in any position, at any angle or slope.

Press  **1f** to enter manual mode. The Manual Mode Indicator **1e** lights up green and **automatic self-leveling is deactivated**.

To reactivate self-leveling mode, press  **1f**.

Slope Mode



The slope of the rotational plane can be adjusted for X-axis and Y-axis.

Aim the X1-beam to the direction of the slope required and allow the instrument to level.

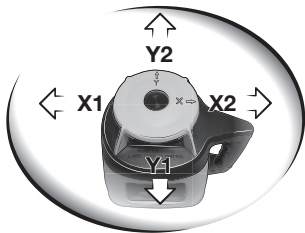

While the instrument is leveled and laser beam is rotating, press  **1f** to switch to Manual Mode.



Adjusting The Slope of Y-Axis

Press  or  **1h** to adjust Y-axis downward or upward. Position the laser beam up or down until the beam slope is set at the desired position.

Adjusting The Slope of X-Axis

For dual slope or grade applications, the X-axis can be adjusted. Press  or  **1g** to adjust x-axis downward or upward. Position the laser beam up or down until the beam slope is set at the desired position.

To deactivate Slope Mode and return to automatic self-leveling operation, press  **1f** again. Allow time for the instrument to self-level.

ACCURACY CHECK

The ambient temperature has the greatest influence. Especially temperature differences occurring from the ground upward can divert the laser beam. The deviations play a role in excess of approx. 65-ft (20m) measuring distance and can easily reach two to four times the deviation at 330-ft (100m). Because the largest difference in temperature layers is close to the ground, the instrument should always be mounted on a tripod when measuring distances exceeding 65-ft (20m). If possible, also set up the instrument in the center of the work area.

Checking the Leveling Accuracy

Apart from exterior influences, device-specific influences (such as heavy impact or falling down) can lead to deviations. Therefore, check the accuracy of the instrument each time before starting your work. A free measuring distance of 100-ft (30m) on a firm surface is required for the check.

- Mount the instrument in the horizontal position onto a tripod or place it on a firm and level surface near wall. Switch the instrument on. Position the X-axis to aim to a wall or target plate.

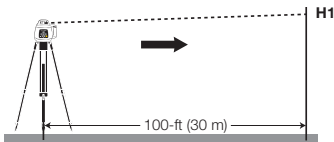

- After the leveling, mark the center of the laser beam on wall (point **H1**).
- Rotate the instrument by 180°, allow it to level in and mark the center point of the laser beam on the wall (point **H2**).

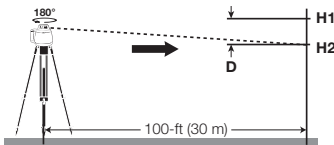

- The difference **D** of both marked points **H1** and **H2** on wall is the actual deviation of the instrument for the measured axis.

The value of **D** (deviation) should be less than 1/8-in (3mm).

If the deviation is more than 1/8-in (3mm), the laser should be sent to your authorized dealer for service and calibration.

RD 200 DETECTOR

The detector aids in locating and targeting a visible or invisible beam emitted by a rotary laser instrument; perfect for use in outdoor conditions, where sunlight and distance may make locating the beam more difficult.

The laser detector includes a rod clamp which allows to mount the detector onto square, round or oval sighting rods.

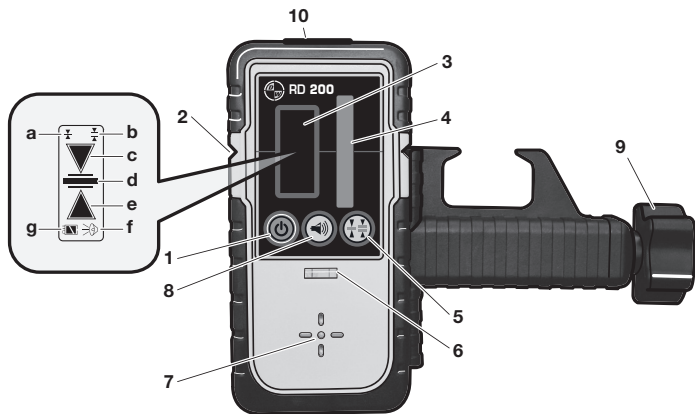

The numbering of the product features shown refers to the illustration of the tool above.

- | | | | |
|------------|-------------------------------------|------------|---|
| 1. | On/Off switch | 3e. | Direction indicator "move upward" |
| 2. | Center mark | 3f. | Audio signal indicator |
| 3. | LCD Display | 3g. | Battery low indicator |
| 3a. | "Fine" adjustment indicator | 4. | Reception area for the laser beam |
| 3b. | "Coarse" adjustment indicator | 5. | Button for adjustment of measuring accuracy |
| 3c. | Direction indicator "move downward" | 6. | Spirit level |
| 3d. | Center indicator | 7. | Speaker |
| | | 8. | Audio signal button |
| | | 9. | Locking screw for leveling rod |
| | | 10. | Magnetic mounts |

RD 200 SERIES PREPARATIONS

Inserting/Replacing the Battery

9V alkaline battery is recommended for the tool.

When the batteries are low, the battery low indicator will display.

Pull the latch of battery lid outward and open the battery lid.

Remove the battery when not using it for extended periods. When storing for extended periods, the battery can corrode and discharge.

MAINTENANCE AND SERVICE

Store and transport the tool only in the supplied protective case.

Keep the tool clean at all times.

Do not immerse the tool into water or other fluids.

Wipe off debris using a moist and soft cloth. Do not use any cleaning agents or solvents.

Regularly clean the surfaces at the exit opening of the laser in particular, and pay attention to any fluff of fibers.

If the tool should fail despite the care taken in manufacturing and testing procedures, repair should be carried out by an authorized after-sales service center for Dave White's SitePro instruments.

In all correspondence and spare parts orders, please always include the

model number and serial number of the instruments.

All precision instruments should be cleaned, lubricated, checked and adjusted ONLY at a qualified instrument repair station or by the manufacturer, at least once a year.

In case of repairs, send in the instrument packed in its protective case.

ENVIRONMENT PROTECTION



Recycle raw materials & batteries instead of disposing of waste. The unit, accessories, packaging & used batteries should be sorted for environmentally friendly recycling in accordance with the latest regulations.

TECHNICAL DATA

KS 100H

Leveling	Horizontal
Horizontal Accuracy	±1/8-in at 100-ft (±3mm at 30m)
Leveling Type	Electronic Self-Leveling (± 5°)
Slope/Grade	Dual Axis -8 % to +8 %
Working Range (dia.)	
With Detector	Up to 1000-ft (305m)
Beam Rating	635-650 nm, Class 2M
Rotation Speed	600 RPM
Power Supply	Four (4) C Cell Alkaline
Operating Time ¹	20 hrs w/alkaline batteries
Environment	IP54, Water/Dust Resistant
Operating Temp.	-4° to 122° F (-20° to + 50° C)
Storage Temp.	-4° to 158° F (-20° to 70° C)
Dimension	6.0 x 8.0 x 7.3-in (152 x 203 x 185mm)
Weight (instrument)	4.4 lb (2.0 kg)

- ¹ Hours are approx. and based on continuous use.
Specifications are subject to change without notification.

GENERAL SAFETY RULES



WARNING

Read all instructions. Failure to follow all instructions listed below may result in hazardous radiation exposure, electric shock, fire and/or serious injury.

All labels on your laser are for your safety and must not be removed. Removing labels increases the risk of exposure to laser radiation. Do not throw this manual away.

If glass light house breaks when dropped, contact customer service immediately. Broken glass can cause laceration hazard and unit to lose its IP rating.



DO NOT direct the laser beam at persons or animals and do not stare into the laser beam yourself. This tool produces laser class 2 laser radiation and complies with 21 CFR 1040.10 and 1040.11 except for deviations pursuant to

Laser Notice No. 50, dated June 24, 2007. This can lead to persons being blinded.

DO NOT remove or deface any warning or caution labels.

Removing labels increases the risk of exposure to laser radiation.

Use of controls or adjustments or performance of procedures other than those specified in this manual, may result in hazardous radiation exposure.

ALWAYS make sure that any bystanders in the vicinity of use are made aware of the dangers of looking directly into the laser tool.

DO NOT place the laser tool in a position that may cause anyone to stare into the laser beam intentionally or unintentionally. Serious eye injury could result.

ALWAYS position the laser tool securely. Damage to the laser tool and/or serious injury to the user could result if the laser tool falls.

ALWAYS use only the accessories that are recommended by the manufacturer of your laser tool. Use of accessories that have been designed for use with other laser tools could result in serious injury or unsatisfactory performance.



DO NOT use this laser tool for any purpose other than those outlined in this manual. This could result in serious injury or unsatisfactory performance.

DO NOT leave the laser tool “ON” unattended in any operating mode.

DO NOT disassemble the laser tool.

There are no user serviceable parts inside. Do not modify the product in any way. Modifying the laser tool may result in hazardous laser radiation exposure.

Work area safety

Keep work area clean and well lit. Cluttered or dark areas invite accidents.

DO NOT operate the laser tool around children or allow children to operate the laser tool. Serious eye injury could result.

DO NOT use instruments, attachments and accessories outdoors when lightening conditions are present.

Electrical safety

Batteries can explode or leak, cause injury or fire. To reduce this risk, always follow all instructions and warnings on the battery label and package.

Remove the batteries from the tool when not using it for extended periods. When storing for extended

periods, the batteries can corrode and discharge themselves.

DO NOT short any battery terminals.

DO NOT charge alkaline batteries.

DO NOT mix old and new batteries.

Replace all old batteries at the same time with new batteries of the same brand and type.

DO NOT mix battery chemistries.

Dispose of or recycle batteries per local code.

DO NOT dispose of batteries in fire. Keep batteries out of reach of children.

Personal safety

Stay alert, watch what you are doing and use common sense when operating a tool. Do not use a tool while you are tired or under the influence of drugs, alcohol or medication. A moment of inattention while operating a tool may result in serious personal injury or incorrect measurement results.

Use safety equipment. Always wear eye protection. Safety equipment such as dust mask, non-skid safety shoes, hard hat, or hearing protection used for appropriate conditions will reduce personal injuries.

DO NOT use the laser viewing glasses as safety goggles. The laser viewing glasses are used for improved visualization of the laser

beam, but they do not protect against laser radiation.

DO NOT use the laser viewing glasses as sun glasses or in traffic.

The laser viewing glasses do not afford complete UV protection and reduce color perception.

DO NOT use any optical tools such as, but not limited to, telescopes or transits to view the laser beam.

Serious eye injury could result.

DO NOT stare directly at the laser beam or project the laser beam directly into the eyes of others.

Serious eye injury could result.

Use caution when using instruments in the vicinity of electrical hazards.

Magnets



Keep the tool and laser target away from cardiac pacemakers.

The magnets of the tool and laser target plate generate a field that can impair the function of cardiac pacemakers.

Keep the tool and laser target away from magnetic data medium and magnetically-sensitive equipment.

The effect of the magnets of the tool and laser target plate can lead to irreversible data loss.

Use and care

Use the correct tool for your application. The correct tool will do the job better and safer.

Do not use the tool if the switch does not turn it on and off. Any tool that cannot be controlled with the switch is dangerous and must be repaired.

Store idle tool out of the reach of children and do not allow persons unfamiliar with the tool or these instructions to operate the tool.

Tools are dangerous in the hands of untrained users.

Maintain tools. Check for misalignment or binding of moving parts, breakage of parts and any other condition that may affect the operation. If damaged, repair tool before use. Many accidents are caused by poorly maintained tools.

Use the tool, accessories, etc., in accordance with these instructions and in the manner intended for the particular type of tool, taking into account the working conditions and the work to be performed. Use of the tool for operations different from those intended could result in a hazardous situation.

SAVE THESE INSTRUCTIONS.

LIMITED WARRANTY

Dave White's SitePro ("Seller") warrants to the original purchaser only, that KS-100H rotary laser tools will be free from defects in material or workmanship for a period of two (2) years from date of purchase.

SELLER'S SOLE OBLIGATION AND YOUR EXCLUSIVE REMEDY under this Limited Warranty and, to the extent permitted by law, any warranty or condition implied by law, shall be the repair or replacement of parts, without charge, which are defective in material or workmanship and which have not been misused, carelessly handled, or misrepaired by persons other than Seller or Authorized Service Center. To make a claim under this Limited Warranty, you must return the complete laser, optical instrument or SitePro product, transportation prepaid, to SITEPRO Service Department or Authorized Service Center. Please include a dated proof of purchase with your tool. For locations of nearby service centers, please call 1-855-354-9881.

THIS LIMITED WARRANTY DOES NOT APPLY TO ACCESSORY ITEMS SUCH AS TRIPODS, RODS, HAND LEVELS, FIELD SUPPLIES, TAPES, MOUNTING DEVICES AND OTHER RELATED ITEMS. THESE ITEMS RECEIVE A 90 DAY LIMITED WARRANTY.

To make a claim under this Limited Warranty, you must return the complete product, transportation prepaid. For details to make a claim under this Limited Warranty please visit www.dwsitepro.com or call 1-855-354-9881.

ANY IMPLIED WARRANTIES SHALL BE LIMITED IN DURATION TO ONE YEAR FROM DATE OF PURCHASE. SOME STATES IN THE U.S., AND SOME CANADIAN PROVINCES DO NOT ALLOW LIMITATIONS ON HOW LONG AN IMPLIED WARRANTY LASTS, SO THE ABOVE LIMITATION MAY NOT APPLY TO YOU.

IN NO EVENT SHALL SELLER BE LIABLE FOR ANY INCIDENTAL OR CONSEQUENTIAL DAMAGES (INCLUDING BUT NOT LIMITED TO LIABILITY FOR LOSS OF PROFITS) ARISING FROM THE SALE OR USE OF THIS PRODUCT. SOME STATES IN THE U.S., AND SOME CANADIAN PROVINCES DO NOT ALLOW THE EXCLUSION OR LIMITATION OF INCIDENTAL OR CONSEQUENTIAL DAMAGES, SO THE ABOVE LIMITATION MAY NOT APPLY TO YOU.

THIS LIMITED WARRANTY GIVES YOU SPECIFIC LEGAL RIGHTS, AND YOU MAY ALSO HAVE OTHER RIGHTS WHICH VARY FROM STATE TO STATE IN THE U.S., OR PROVINCE TO PROVINCE IN CANADA AND FROM COUNTRY TO COUNTRY.

THIS LIMITED WARRANTY APPLIES ONLY TO PRODUCTS SOLD WITHIN THE UNITED STATES OF AMERICA, CANADA AND THE COMMONWEALTH OF PUERTO RICO. FOR WARRANTY COVERAGE WITHIN OTHER COUNTRIES, CONTACT YOUR LOCAL SITEPRO DEALER OR IMPORTER.



Dave White's

SiteProTM

Dave White's SitePro LLC
Lafayette, IN USA

www.dwsitepro.com

© 2018-2019 copyright Dave White's SitePro LLC. All rights reserved.

SitePro and the Aperture & D W logo are trademarks of Dave White's SitePro LLC, in the United States and in other countries. The David White brand and logo are exclusive to Dave White's SitePro. All other trademarks are the property of their respective owners. Design and specification of products are subject to change without notice.